

On the process

FIXOLITE VR

Product family/Process: Roller shutter box integrated into masonry

Holder(s): Company FIXOLITE SA

FOREWORD

Technical opinions and technical application documents, hereinafter referred to interchangeably as Technical Advice, are intended to provide construction stakeholders **with elements of assessment on the suitability for use of products or processes** whose constitution or employment does not fall within traditional know-how and practices.

This resulting document must be taken as such and is therefore not **a document of compliance with regulations or a "quality mark"** benchmark. Its validity is decided independently of that of the supporting documents in the technical file (in particular any regulatory certificates).

The Technical Assessment is a voluntary approach by the applicant, which in no way changes the distribution of responsibilities of construction stakeholders. Regardless of the existence or not of this Technical Approval, for each work, the actors must provide or request, depending on their roles, the required supporting documents.

As the Technical Notice is aimed at actors reputed to know the rules of the art, it is not intended to contain any information other than that relating to the non-traditional nature of the technique. Thus, for aspects of the process that comply with recognized rules of the art for implementation or sizing, a reference to these rules is sufficient.

Specialized Group No. 16 - Special products and processes for masonry

Document Versions

Version	Description	Rapporteur	President
V5	<p>This version, examined by GS n° 16 on 05/10/2023, cancels and replaces Technical Notice n° 16/11-634_V4. It incorporates the following modifications:</p> <ul style="list-style-type: none">• Modification of the figures to improve their readability.• Conversion of the Technical Approval according to the new frame.• Replacement of the term "undercoating" by "primary protection".	AKKAOUI Abdessamad ESTEVE	Stéphane

Descriptor:

Prefabricated roller shutter box, made by molding an expanded polystyrene body in the shape of an inverted U, the vertical faces of which are covered with wood wool plates (Fibragglo), terracotta facings or a protective primer. The polypropylene side panels are fitted with supports for fixing to the structural work. The box can be installed either during assembly of the supporting wall, or after finishing the structural work by fixing under the lintel and existing ceiling.

Contents

1.	Opinion of the Specialized Group.....	5
1.1.	Accepted field of employment.....	5
1.1.1.	Geographical area	5
1.1.2.	Works covered	5
1.2.	Appreciation	5
1.2.1.	Suitability for use of the process	5
1.2.2.	Sustainability	6
1.2.3.	Environmental impacts.....	6
1.3.	Additional remarks from the Specialized Group.....	6
2.	Technical file	7
2.1.	Marketing method.....	7
2.1.1.	Contact details.....	7
2.1.2.	Identification.....	7
2.2.	Description.....	7
2.2.1.	Principle.....	7
2.2.2.	Characteristics of the components	8
2.3.	Design provisions.....	13
2.4.	Implementation arrangements.....	13
2.4.1.	Preparing the chests	13
2.4.2.	Installation method.....	13
2.4.3.	Seismic treatment.....	15
2.4.4.	Connection of joinery.....	15
2.4.5.	Air permeability	16
2.4.6.	Sous-face (cf. Figure 37).....	17
2.4.7.	Adjustable sunshade boxes	17
2.4.8.	Coatings.....	17
2.4.9.	Interior finishes.....	18
2.5.	Maintaining the process in service	18
2.6.	End-of-life treatment.....	18
2.7.	Assistance technique	18
2.7.1.	For sale.....	18
2.7.2.	During manufacturing.....	18
2.7.3.	On site.....	18
2.7.4.	A distance.....	18
2.8.	Principles of manufacturing and control of this manufacturing	18
2.8.1.	Fabrication.....	18
2.8.2.	Controls.....	19
2.8.3.	Storage – Delivery (see Figure 42)	20
2.8.4.	Commercialisation.....	20
2.8.5.	Assembly at the distributor.....	20
2.8.6.	Mounting the roller shutter.....	20
2.8.7.	Packaging and transport.....	20
2.8.8.	Storage on site	21
2.9.	Mention of supporting documents	21
2.9.1.	Experimental results	21
2.9.2.	Construction site references	21
2.10.	Annex to the Technical File – Implementation diagrams.....	23

1. Opinion of the Specialized Group

The process described in chapter 2 "Technical File" below was examined by the Specialized Group which concluded favorably on its suitability for use under the conditions defined below:

1.1. Accepted field of employment

1.1.1. Geographical area

The Notice is formulated for use in mainland France.

1.1.2. Works covered

All exposure zones within the meaning of NF DTU 20.1 Part 3 for boxes installed during the construction of the structural work, situation d not being covered in the case of installation by fixing under the slab. The use of boxes for facades mentioned in chapter 1.2.1.2 "Safety in the event of fire" below is not covered by this Technical Notice.

The maximum overall length of the trunk is 4740 mm.

The maximum bay opening length is 4500 mm.

Establishments open to the public requiring fire reaction classification for facade coverings are not targeted.

1.2. Appreciation

1.2.1. Suitability for use of the process

1.2.1.1. Stability

The "FIXOLITE VR" boxes have a mechanical resistance enabling them to meet specific requirements concerning joinery assemblies and relating to resistance under wind loads. The planned reinforcements are described in paragraphs 2.2.2.1 and 2.4.4.2 of the Technical File

The chest alone cannot be considered load-bearing.

1.2.1.2. Fire safety

Reaction to fire:

Brick is deemed to be non-combustible according to the amended decree of November 21, 2002 relating to the reaction to fire of construction and development products.

FIXOLITE VR boxes cannot be installed on a facade whose openings must demonstrate a degree of fire resistance.

For use in facades with openings and having to comply with the "C + D" rule relating to the propagation of fire, FIXOLITE VR boxes cannot be taken into account in the calculation of the C value.

1.2.1.3. Acoustic insulation

The system is classified ESA4 within the meaning of the examples of acoustic solutions from January 2014 and therefore does not prevent compliance with the requirements of the decrees of June 30, 1999 relating to residential buildings, and of April 25, 2003 relating to hotels, establishments of education, and health establishments. The ability of the building to respect the facade insulation level for regulatory requirements of 30 dB, 35 dB and 38 dB can be examined using the Examples of Acoustic Solutions from January 2014 published by the Ministry of Equipment, transport and housing.

In the case of higher regulatory requirements, for example for buildings near noisy land transport infrastructure or airport areas, a calculation (according to EN 12354-3) will be necessary.

The performance of the safe to be taken into account in the event of calculations is given in the reports cited in § 2.9.1 of the Technical File.

1.2.1.4. Finishes – Appearance

The trunk linings are suitable for receiving the usual finishes on wood wool and protective primer. The coating to use is the one that matches the rest of the facade.

1.2.1.5. Thermal insulation

The average surface transmission coefficients U_c are given in the report cited in § 2.9.1 of the Technical File. The thermal conductivity of the polystyrene part is 0.0374 W/mK (after application of the safety coefficient of 1.15).

1.2.2. Sustainability

Expanded polystyrene allows you to expect good behavior over time. There is no incompatibility between the materials of the box and the adjacent materials.

Concerning fibragglo, the experience gained from its use in buildings allows us to expect good behavior over time, as long as the exterior coatings are correctly executed.

The provisions planned which consist of reinforcing both interior and exterior coatings with a mesh (see § 2.4 of the Technical File) are suitable for limiting, in current dimensions, the risk of cracking resulting from differential dimensional variations between support materials. 'coated. In this regard, exterior coatings in dark colors should be avoided. Coatings with a solar radiation absorption coefficient greater than 0.7 are not covered.

1.2.3. Environmental impacts

The process does not have any Environmental Declaration (DE) and cannot therefore claim any particular environmental performance. Please note that DEs do not fall within the scope of examination of suitability for use of the process.

1.3. Additional remarks from the Specialized Group

The group wishes to draw attention to the need to use the reinforcements provided for in the Technical File as soon as the opening exceeds the width of 1.6 m.

Attention is required on the need to quickly protect the box after its installation with a protective layer against moisture absorption while the finishing coating is applied.

2. Technical File

From the elements provided by the holder and the requirements of the Specialized Group accepted by the holder

2.1. Marketing method

2.1.1. Contact details

The process is marketed by the holder.

Holder: FIXOLITE SA

Rue Vandervelde 170

BE - 6230 THIMEON

Such. : +32 71 25 87 90

Email: info@fixolite.be

2.1.2. Identification

The chests are identified by the FIXOLITE brand appearing on the sides of the chest.

Marking

The cheeks are marked FIXOLITE

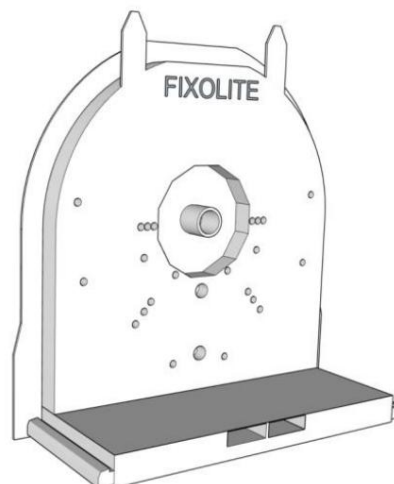

Figure 1 – Fixolite cheek

2.2. Description

2.2.1. Principle

The FIXOLITE VR box is a prefabricated lintel box intended to receive a closure, made of an expanded polystyrene shell in the shape of an inverted U.



Figure 2 - Fixolite box with fiber finish The interior

vertical faces have an embossed polystyrene finish.

The exterior vertical faces have a raised polystyrene finish or are covered with fiber boards, terracotta or with a protective primer intended to receive coatings.

The boxes (without reinforcement) will be used for a width less than or equal to 1.6 m table.

To allow the use of boxes without reinforcement for widths of 1.2 m to 1.6 m, the inertia of the upper cross member must be at least 3.5 cm⁴.

Reinforced boxes will be used for tables with widths greater than 1.6 m and less than or equal to 4.5 m. Reinforced boxes can also be used for widths less than 1.6 m.

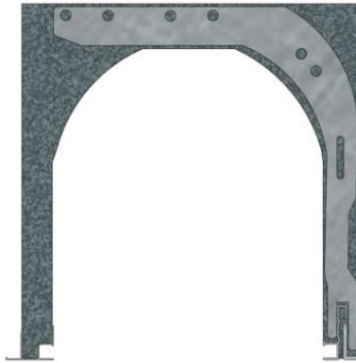

Figure 3 - Reinforced trunk and its reinforcement

Four models of chests are offered:

- The **traditional** range (T) with an interior wall of 25 to 28 mm. (see Figure 18) • The **high insulation** range (Hi) with an interior wall of 33 mm for type 28 and 31 boxes, wall of 53 mm for types 30 and wall of 91 mm for type 36 boxes. (see . Figure 19)
- The **reinforced** range (R) has the same width as the Hi range but a greater height for the integration of reinforcements every 1.2 m. The reinforced boxes will be used for paintings up to 4.5 m wide. (See Figure 20)
- For the T (traditional), Hi (high insulation) and R (reinforced) ranges, the polypropylene side panels are fitted with fixing supports to the structural work.
- The **adjustable sunshade** (BSO) range has an interior wall of 45 mm for type 230 and 95 boxes mm for types 280. Type 280 can be adapted for an internal wall of 115 mm. These chests have the same steel mesh as the other chests. To attach the BSO, a continuous, full-length aluminum profile is integrated into the trunk roof. For the breeze sun range, the cheeks are made of polystyrene. (see Figures 21 and 22)

2.2.2. Component characteristics

2.2.2.1. General composition

The element consists of a U-shaped molded polystyrene shell reinforced by a steel mesh.

The two side wings can be covered externally with wood fiber cement plates, terracotta or a protective primer and internally with an embossed polystyrene finish.

Two section reservations 80 x 30 x 35 mm (L x W x H) every 300 mm will receive the concrete for the lintel which will anchor the box.

Plastic side panels close the ends of the element and include the roller shutter fixing devices. The heel of each face is capped by an aluminum profile serving as a stop for the finishing coatings and to hold the underside in place.

2.2.2.1.1. Chest

BASF polystyrene, ref. 214, PCS Styropor (higher combustible power) 41 MJ/kg, density of 30 ÷ 2 kg/m³.

For differentiation purposes, gray graphitized polystyrene will be used for the reinforced boxes.

In order to avoid reflections through the BSO slats, gray graphitized polystyrene will also be used for these boxes.

2.2.2.1.2. Welded Mesh

Raw or galvanized, smooth, ribbed or galvanized wire from 3 to 6 mm with 4 to 10 longitudinal wires. Cross wires spaced every 300 mm.

2.2.2.1.3. Aluminum or PVC profiles

Delivered raw, with groove to receive the underside and clip the cheeks at each end of the box cut to length.

- **Exterior (or interior) rails** with facade coating stop wing and grooves for attaching coatings.



<p>827</p>  <p>Exterior rail for all types of chests. Can also be used as an interior rail.</p>	<p>830</p>  <p>Alternative to rail 8, with deeper soffit notch.</p>	<p>8F</p>  <p>Allows the fixing of the rail cover</p>
---	---	---

Table-1 - Aluminum profile with coating support (exterior)

• **Interior rails** without facade plaster support.





<p>8H</p>  <p>Standard rail of traditional chests</p>	<p>8L</p>  <p>Similar to 8H rail, with grooves</p>
<p>8E</p>  <p>For high insulation boxes, allows the thermal bridge to be broken</p>	<p>8R</p>  <p>For high insulation boxes, allows the thermal bridge to be broken and a sealing angle to be inserted.</p>
<p>BSO-FX</p>  <p>Central rail of BSO boxes Allows the flap to be fixed all along the trunk</p>	<p>BSO-FT</p>  <p>Central rail of BSO boxes Allows the flap to be fixed all along the trunk with nut slider</p>
<p>PL</p>  <p>PVC rail for BSO box with tongue</p>	<p>PG</p>  <p>PVC rail for BSO box with slide</p>

Table-2 - Aluminum profile without coating support

2.2.2.1.4. Reinforced chests

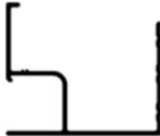
The reinforced boxes - for paintings from 1.6 to 4.5 m - are equipped with steel brackets and a U-shaped steel rail.

The 3 mm thick galvanized steel brackets (20 µm thick) are positioned in the mold before the expansion of the polystyrene. They are present in the trunk with an interval of 1.2 m. (see Figure 23).

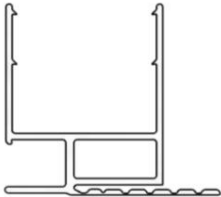
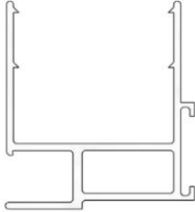
No mechanical connection is provided between the brackets and the trellis. The reinforcements are perforated to allow cohesion with the polystyrene during manufacturing. (see Figure 24)

The U-shaped galvanized steel reinforcement rail (thickness 20 micrometers) is also positioned in the mold before the expansion of the polystyrene. The length of the U-rail is the same as the length of the boxes. (see Figure 25). The reinforcement brackets are fitted into the U and the aluminum profile to ensure mechanical resistance.

Reinforced boxes are always delivered with the brackets and U reinforcement fitted. The steel of the brackets has the following mechanical properties:

- Rel (Elastic limit): 333 MPa

- Rm (Tensile strength): 417 MPa • A80
- (Elongation at break): 22.00% • A5 (Elongation at break): 21.99%

2.2.2.2. Finishes

2.2.2.2.1. Basic finish (exterior and interior)

Embossed polystyrene finish:



Figure 4 - Ribbed or structured polystyrene finish

BASF polystyrene, ref. 214, Styropor from PCS.

The relief of this finish (structured or ribbed) is obtained during the manufacture of the chests using a matrix placed in the mold.

2.2.2.2.2. Exterior finishes

As an option, three types of finish are available:

Primary protective finish:



Figure 5 - Primary protective finish

The protective and adhesion primer improves adhesion before application of the final coat with resinous and mineral coatings. It is absorption regulator, permeable to water vapor, water repellent.

This product is a component of the basic -AKS exterior insulation system with a European Technical Assessment: ETA-11-0386 of 10/28/2016

Properties :

- o Constitution: quartz sand, pigments (gray, terracotta, blue), terpolymer resin dispersion and additives
- o Density (kg/m³): 1.70 ± 0.1
- o Dry extract at 105°C (t105) (%): 80.2 ± 2
- o Ash rate at 450°C (t450) (%): 71.2 ± 2
- o VOC value (Volatile Organic Compounds): < 10 g/l (EU limit value for the content of VOC of this product (cat. A/h) is 30 g/l.
- o Product: HAFTGRUND P.

Fiber finish:**Figure 6 - Wood-cement fiber finish**

- o Wood-cement board (fibraggio), thickness of 5 to 8 mm, density 600 kg/m³ in compliance with the standard NF EN 13168.

Brick finish:**Figure 7 - Brick finish**

- o Terracotta plate, thickness of 8 mm ± 1 mm.
- o Weight: approximately 4 kg/meter.
- o Complies with standard NF EN 771-1.
- o Width: 240 to 290 mm, Length: 495 mm +5-0 mm
- o Pull-out strength (MPa): > 0.2 N/mm²

2.2.2.3. Side cheeks

Polypropylene material with talc injected under pressure. Cheeks with integrated bases forming a rigid bracket.

The cheeks can receive different ends for fixing the roller shutters or the soffit.

For BSO chests, the sides are made of polystyrene:

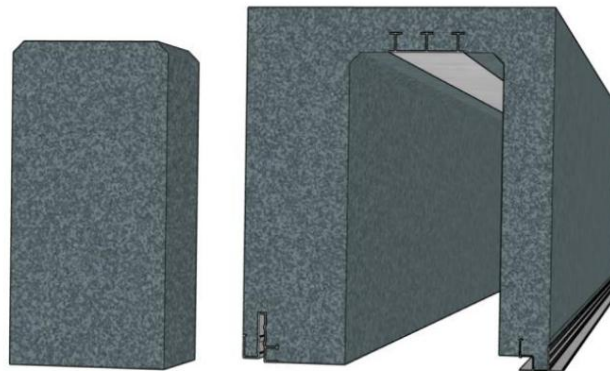
**Figure 8 - Polystyrene cheek (density 40) for BSO box****2.2.2.4. Accessories****2.2.2.4.1. Inspection hatches and rail covers**

The inspection hatches (or soffit) are made of white PVC.

Two soffit models (figure 37):

- SF7 soffit and CR7 rail cover compatible with profiles 7. The SF7 is also available in one piece with integrated rail cover (width of 220 mm)
- SF8 soffit and CR8 rail cover compatible with profiles 8.

The soffits can receive insulation which will be glued or screwed onto them. This insulation will improve the thermal performance of the trunk.

For panel widths greater than two meters, the use of squares will be recommended to allow the assembly to be stiffened (see figure 9).

2.2.2.4.2. Joinery fixing reinforcement

Reinforcement (patented) in 3 mm galvanized steel and fixing brackets without screws for panels from 1.6m to allow the joinery to hold to the concrete lintel, without support on the box (figure 40). To be placed every 90 to 120 cm. Weight: 1.2 kg/piece. This reinforcement does not strengthen the trunk and does not replace the reinforced trunk for paintings over 160 cm.

2.2.2.4.3. Sealing kit

The rail/woodwork seal allows you to fill a space of between 5 and 25 mm between the box and the woodwork. The sealing pad is positioned in the heel of the cheek to treat air passages at the top of the taps.

2.2.2.4.4. Soffit bracket

For panel widths greater than two meters, the use of underside brackets will be recommended to allow the assembly to be stiffened.



Figure 9 - Soffit bracket fixed on the rail

2.2.2.5. Dimensions

In the standard offer, FIXOLITE VR boxes are delivered in lengths of 6 m in the following widths: 250, 270, 280, 300, 330, 350, 360, 380, 420 and 490 mm.

BSO boxes are delivered in widths of 230 and 280 mm.

Reinforced chests must be used for tables with widths greater than 1.6 m (179 cm chest) and less than or equal to 4.5 m (469 cm trunk).

Traditional models	Height	Width	Paris ext.	Tunnel	Inner wall.
25 H 25	245	245	24.5	196	24.5
28 H 29	285	278	24	230	24
28 H 30	295	278	24	230	24
30 H 30	295	298	26	246	26
High insulation models	Height	Width	Paris ext.	Tunnel	Inner wall.
28 S 29	285	280	25	222	33
30 S 29	285	300	25	222	53
31 S 30	295	306	26	246	34
Reinforced models	Height	Width	Paris ext.	Tunnel	Inner wall.
R 28 S 29	292	280	25	222	33
R 30 S 29	292	300	25	222	53
R 31 S 30	302	306	26	246	34
BSO models	Height	Width	Paris ext.	Tunnel	Inner wall.
BSO 23 H 32	320	230	45	140	45
BSO 28 H 32	320	280	45	140	95
BSO 28 H 29	285	280	26	140	114

Table 4 - Dimensions of chests

2.2.2.6. Thermal performance

Model	Profile	Width	Thermal transmission coefficient U _c (W/m ² .K)		Reinforcement coefficient	
			Winding Interior	Outer winding		
Traditional	GO	23	1.60	1.00		
		28	1.40	0.90		
		30	1.30	0.75		
		36	1.10	0.60		
Haute isolation	PVC	28	0.70	0.67		
		30	0.51	0.49		
		36	0.30	0.29		
	GO	28	0.73	0.70		
		30	0.51	0.50		
		36	0.31	0.30		
Reinforced	PVC	28	0.97	0.77		0.02
		30	0.58	0.55		0.02
		36	0.32	0.30	0.14	
	GO	28	0.88	0.82	0.02	
		30	0.60	0.58	0.02	
		36	0.61	0.30	0.01	

2.3. Design layouts

The box must be installed on a window whose upper crosspiece of the frame associated with the soffit has sufficient rigidity so that the deflection of this element remains less than 1/150th of the span under the pressure of the deformation P1 of the site as defined in document FD P 20-201, without exceeding 15mm under 1600 Pa.

It is necessary to use the reinforced boxes provided in this Technical File as soon as the opening exceeds the width of 1.6m. For reinforced boxes, the width of the bay must be 4.5 m maximum (box 4.69 m).

The joinery element closing the trunk must be designed to allow accessibility to the roller shutter mechanisms and dismantling of the apron.

2.4. Implementation arrangements

2.4.1. Preparing the chests

- Normally, the boxes are delivered to length and equipped with side panels. The box is twice the length of the heel of the cheeks - i.e. 190 mm (2 x 95) or 130 mm (2 x 65) depending on the type of cheek - than the width of the finished opening (with finishing coating).
- Once the trunk has been cut, the assembler must mount the

cheeks on the ends of the trunk:

1. Spread the trunk wings using a spacer.
2. Integrate the cheek into the trunk in order to put the joint in compression. (see Figure 26)
3. Remove the spacer to allow the cheek to be clipped into the interior and exterior profiles.

For BSO boxes, after the box has been lengthened, the polystyrene cheeks are glued with silicone glue or with one-component polyurethane glue.

At this level of manufacturing the box can be delivered to the site.

2.4.2. Installation method

In the case where the box is fixed after execution of the lintels or under the floor, all provisions must be made to avoid cutting the frames; gun nailing is not covered.

The fixings, placed in a staggered pattern, will be placed 30 cm from the ends and their spacing will not exceed 0.60 m.

2.4.2.1. Installation during construction of the structural work (most common case)

The installation operations are carried out by the mason who, once the legs have been raised to the required level, prepares the seat of the box with a bed of mortar. If necessary, in the case of thick insulation, additional insulation is glued to the face of the box using polystyrene glue.

For interior insulation (ITI), the exterior wing of the box will be placed in alignment with the exterior wall. (see Figure 27)

For exterior insulation (ITE), the interior wing of the box will be placed in alignment with the interior wall. (see Figure 28)

Alignment

- Whatever the installation method envisaged, the sides of the box must be braced, kept in alignment by nails or battens during the installation operation.
- The chests must be leveled and plumbed. • In case of interior insulation (ITI) and application of a gobetis on the exterior face of the box - mandatory for the box must be set back 3 to 5 mm from the fiber finish -, exterior wall. • Connection to the structural work is ensured by filling the openings in the shell, when the lintel and/or floor is poured. For good filling of the reservations, the concrete must be of fine grain size (< 10 mm).
- The end cheeks which transmit the loads of the roller shutter to the structural work must rest on surfaces hard, flat and strictly level.
- The cheeks rest on a mortar which ensures the waterproofing of the connection between the heel of the cheek and the masonry (cf. Figure 29).
- The edge of the heel of the cheek must be aligned with the finishing coating (the length of the trunk must take into account the heel of the cheeks and the finishing coating). (see Figure 29)
- A space of 5 to 15 mm must be provided between the box and the frame of the joinery.

Shoring

Two rails will be positioned under the trunk and held in place by two clamps. Crosspieces will be positioned on these bastainings with a maximum center distance of 60 cm. A crosspiece will be positioned close to the cheek in order to avoid stressing the cheek. (see Figure 30)

The shoring will then be done under the bastainings every 60 cm.

The shoring will be maintained for 28 days after pouring the concrete.

Box/masonry connection

The upper face of the box has multiple reservations to receive the concrete from the lintel creating a mechanical connection during the pouring of the concrete.

For reinforced boxes: the reinforcement brackets are positioned in the mold before polystyrene injection. The brackets are released at the top to ensure the connection to the chaining.

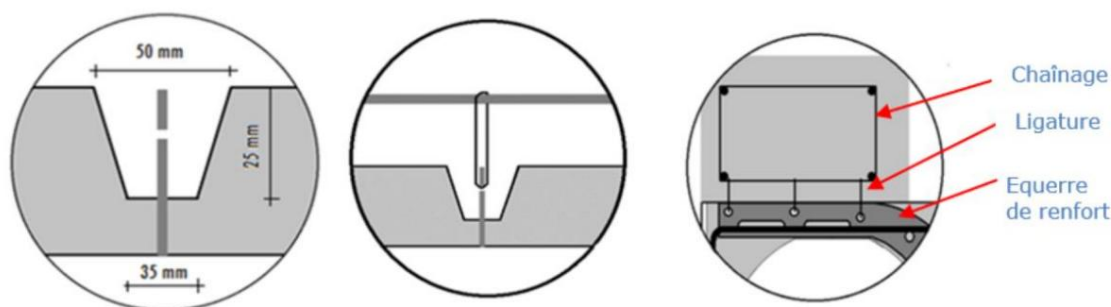
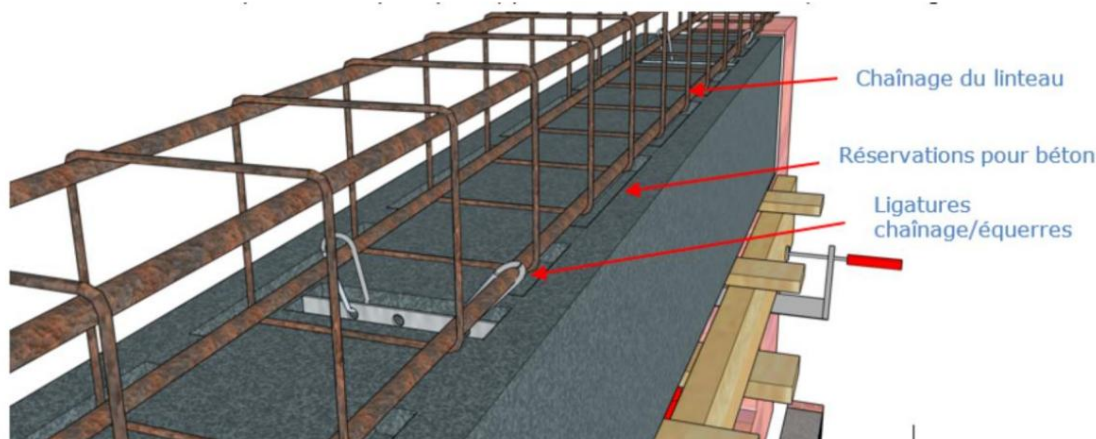

Figure 10 - Reinforced boxes: remove the polystyrene reinforcement brackets before installing ligatures

The reinforcement/chaining connection will be ensured by a ligature (galvanized iron wire with a minimum diameter of 2.5 mm). At least two ligatures must connect each of the brackets. Each square, positioned every 120 cm, must be tied.



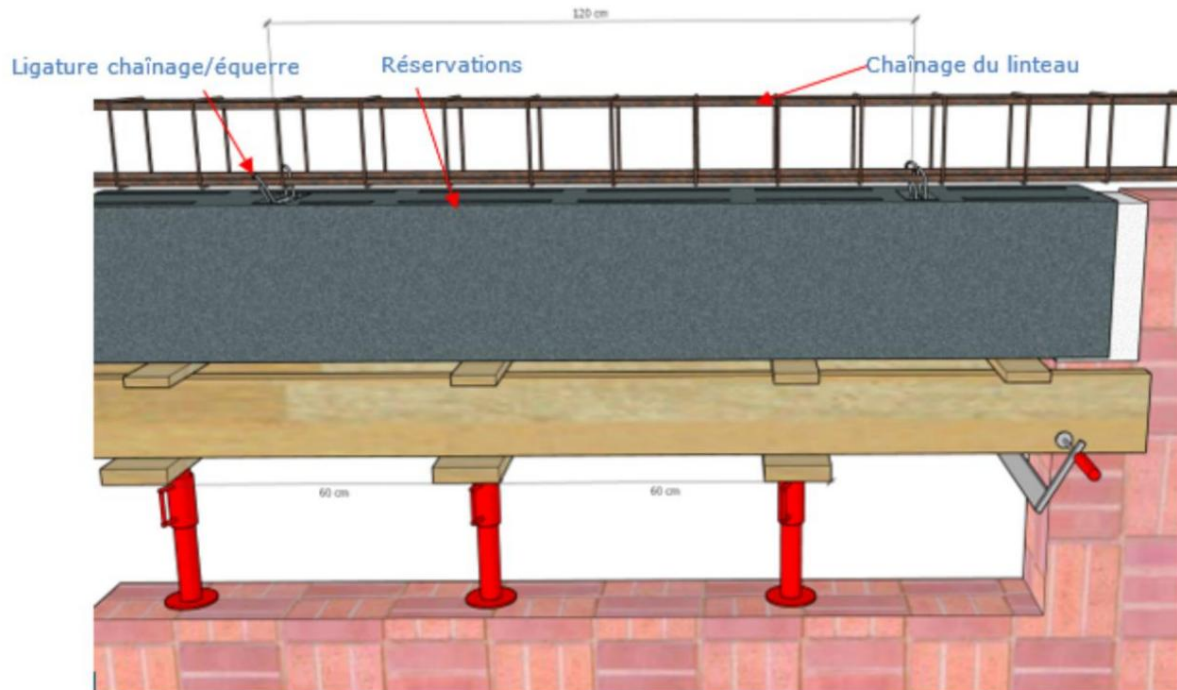

Figure 11 - Reinforced chests: binding of the reinforcements at right angles to the chaining

For unreinforced boxes, it is also possible to tie the reinforcing mesh to the chaining by digging lightly into the polystyrene.

2.4.2.2. Installation under slab

This installation method is mainly found in the case where the structural work is carried out using industrialized techniques. Installation under slab is limited to 1600 mm (reinforced boxes or not).

The box is fixed to the concrete using galvanized lag bolts of \dot{y} 8 mm (with washers \dot{y} 50 mm) (NFA 91-121 standard), positioned at the bottom of the shell, distributed every 60 to 80 cm and screwed into dowels installed in concrete. Lag screws and washers are the responsibility of the installer. (see Figure 31)

A bonding product, previously deposited on the upper part of the box, completes the fixing and ensures sealing with the structural work. This product (adhesive mortar) is chosen from those used in exterior insulation systems (polystyrene/concrete) benefiting from a valid Technical Approval.

2.4.3. Seismic treatment

According to current regulations, it is possible to arm openings equipped with lintel boxes (see Figure 32). The diameters, number or locations of the concrete bars will be defined by a concrete study.

2.4.4. Connection of joinery

2.4.4.1. Unreinforced chests

For non-reinforced boxes, the joinery is directly connected to the interior face of the box and located directly above it. (see Figure 35)

2.4.4.2. Reinforced chests

The boxes are delivered equipped with reinforcement brackets with steel U (thickness of 3 mm) during the manufacturing of the boxes

Workshop preparation: no specific preparation, the brackets and steel U being integrated into the trunk

Completion on site: joinery box connection with reinforced box with a box/woodwork connection tab

- For aluminum and PVC profile: the connecting bracket is made from galvanized sheet metal 40 mm high, 30 to 45 mm deep and 1.5 mm thick. It is made with an oblong hole at the top to allow adjustment between the box and the joinery. Two holes have been provided to allow adjustment of the fixing during installation.

- The connecting brackets will be fixed with a maximum center distance of 400 mm. • For

boxes with aluminum profile, 4.8 sheet metal screws will be used to mount the connecting bracket. The connecting tabs will be fixed to the steel U-shaped and the upper crossbar of the joinery by screwing. (see Figure 36) • For boxes with PVC profile: the

connecting tabs will be fixed to the PVC profile using clamps. For the joinery leg connection, 4.8 sheet metal screws will be used.

Fixing will be done by screwing with a center distance of 400 mm on the upper crossbar of the joinery. This pause mode is also applied to non-reinforced chests.

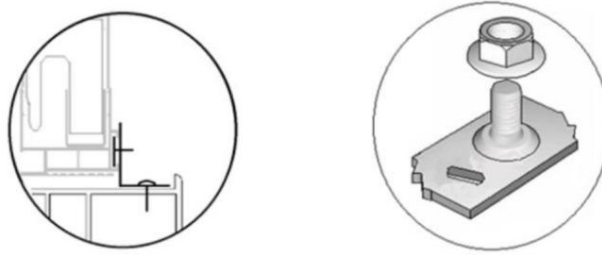

Figure 12 - Connecting bracket and clamp for PVC profile

2.4.5. Air permeability

Cheek treatment:

The side panels for chests with a 222 mm or 230 mm tunnel are equipped with a flexible lip (patented) and do not require any treatment.

For the other cheeks, before mounting the cheek on the trunk, apply an EPDM seal or an acrylic seal.

Trunk/transom joinery connection treatment with joint:

- Box/carpentry connection: a foam pad will be positioned in a socket in the cheek directly above the typed.
- The sealing kit (gasket/buffer) will be supplied as an accessory. The joint can be cut to size or delivered under 50 ml drum shape. However, for the joints supplied cut, it is recommended to provide them 20 mm longer, they are adjusted on site.

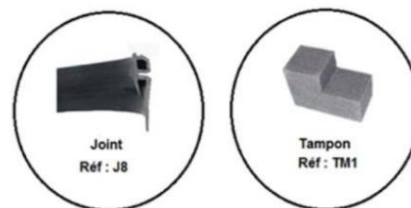

Figure 13 - Sealing kit: J8 seal and TM1 buffer

Completion on site

- Joint: it will be cut to the width of the panel and positioned in the notch of the aluminum profile on the boxes. It will ensure the waterproofing of the transom/joinery connection. A PVC angle can also complete the waterproofing of the whole

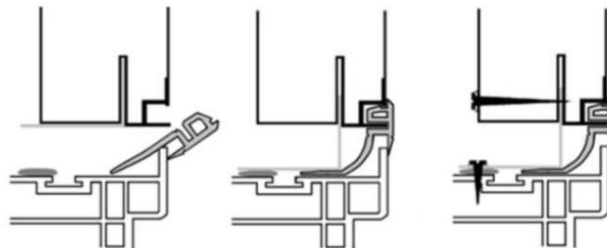

Figure 14 - J8 seal and PVC angle

- Buffers: a buffer must be positioned above the tap to ensure the tightness of the tap connection carpentry (two stamps per carpentry).

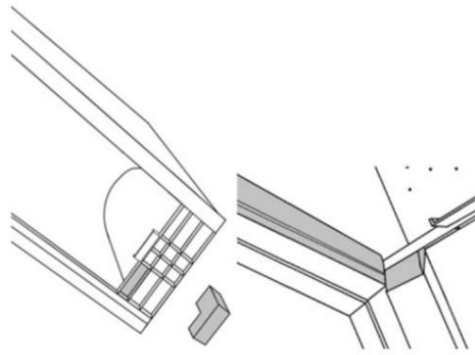

Figure 15 - Air seal pad

2.4.6. Sous-face (cf. Figure 37)

- The soffit is installed after the shutter, the joinery and the coating have been installed. • The underside is intended to close the opening of the trunk, thus making the interior part of the trunk invisible.
- The soffit must be removable in order to be able to carry out subsequent intervention (troubleshooting or maintenance).

There are several variations for fixing the soffit:

- The fixed or mobile bracket: fixing is done by screwing (4x20 stainless steel or galvanized screws standard NFA 91-121). (see Figure 38)
- Locks. Fixing is done by sliding the lock. No screws are used. This binding is the most recommended, it allows multiple assembly and disassembly without damaging the underside. (see Figure 39)

Beyond 2 m the soffit must be reinforced using soffit brackets according to the distribution below:

Table width (cm)	Number of brackets
From 0 to 199	0
From 200 to 299	1
From 300 to 360	2

Table 5 - Distribution of soffit brackets

Depending on the nature of the soffit, it must meet the specifications of the DTU "Joineries" concerning it.

2.4.7. Adjustable sunshade boxes

For sunshade boxes, the polystyrene panel (density 40 kg/m²) must be glued to the box with silicone or one-component polyurethane (PU) glue.

The seal under the cheek is ensured by the cement mortar on which the box is placed.

A support bracket will be screwed into the profile every 70 cm with 2 screws 30 mm apart. (see Figure 41)

2.4.8. Coatings

2.4.8.1. Internal thermal insulation (ITI)

The outer wing of the box will be systematically covered continuously with a layer of gobetis type mortar 3 to 5 mm thick (see chapter of NF DTU 26.1) or specific ready-to-use mortars at the time of installing the trunk.

The coatings are applied to a dry surface. It is necessary to ensure beforehand that the faces of the aluminum profile have been roughened to the right of the jambs (applies to the exterior side for installation with insulation from the inside) (see Figure 33)

This layer of mortar will be made rough (grainy or streaked appearance) so as to improve adhesion with the layer of rendering mortar which will be applied subsequently.

The exterior boxes will be covered with the same coating as that chosen for the masonry.

The coatings will be either:

- Performance mortars of single-layer type (OC) or standard type (GP),
- Recipe mortars, made on site or in the factory, complying with NF DTU 26.1.

These coatings must incorporate a reinforcing frame conforming to standard NF DTU 26.1 P1-2, chapter 7. This frame must not be placed on the support but must be integrated into the coating and must cover the entirety of the box overflowing at least 15 cm on the masonry.

A strip of corner reinforcement reinforcement of minimum size 50 x 30 cm will be positioned diagonally at each end of the box.

The reinforcement used will be of type:

- Reinforcement in alkali-resistant treated glass mesh, installed by marouflage in a first pass or layer of coating. (see Figure 34)

2.4.8.2. External thermal insulation (ITE)

The trunk will be covered with the same insulation as the facade. The coating will be applied using the same method as the rest of the facade.

2.4.9. Interior finishes

- Plaster coating sprayed according to the requirements of standard NF DTU 25.41.
- Plasterboards glued according to the requirements of standard NF DTU 25.41.

2.5. Maintaining the process in service

The process does not require any special maintenance. If the roller shutter mechanism integrated into it requires servicing for maintenance or repair, the inspection is carried out in the lower part by removing the soffit.

2.6. End of life treatment

No information was provided for end-of-life treatment.

2.7. Assistance technique

2.7.1. For sale

The sales representative validates the choice of safe with the customer. Whether on the trunk models or the fiber or brick exterior finishes.

2.7.2. During manufacturing

The customer can contact Fixolite for processing questions, such as flow lengths, tooling, storage of boxes before and after machining and mounting of cheeks.

Please remember that it is during manufacturing that the reinforcements are installed for boxes with a width greater than 1.6 m.

2.7.3. On site

After implementation on the site, Fixolite offers technical assistance by providing its expertise to validate the conformity of the implementation.

2.7.4. A distance

E-mail: info@fixolite.be or +32 71 25 87 90 or on our [website Fixolite.be](http://www.fixolite.be)

2.8. Principles of manufacturing and control of this manufacturing

2.8.1. Fabrication

Manufacturing includes two phases:

- Creation of the hulls and side panels,
- Assembly of these components and equipment.

The hulls are manufactured by the company FIXOLITE USINES SA in Thiméon, Belgium.

2.8.1.1. Manufacturing of terracotta plaques

The terracotta slabs for the brick finish are manufactured by extruding a clay paste as for hollow terracotta elements.

At the end of the extrusion die, the elements 24 to 29 cm wide and 40 mm thick are cut to a length of 500 mm, then dried and baked.

The 8 mm plates are obtained by separating the exterior faces of the 50 x 28 x 4 cm elements. The plates are covered with glue and then palletized.

Manufacturing is carried out by the company ESSE ELLE LATERIZI, Italy).

2.8.1.2. Manufacturing of Fibragglo panels

Wood-cement panels are made of wood mixed with cement and compressed (according to standard EN 13168).

The panels are 5 to 8 mm thick and have a density of 600 ± 30 kg/m³. Dimensions may vary depending on the supplier, most often: 200 x 60 cm).

Manufacturing is carried out by the KNAUF Company.

2.8.1.3. Manufacturing of the protective primer

Product: HAFTGRUND P., manufacturing is carried out by the ALSECCO Company.

The protective primer is manufactured by mixing the different constituents: quartz sand, pigments (gray, terracotta, blue), resin dispersion, additives.

2.8.1.4. Creation of the hulls

After expansion, the polystyrene granules are stored in holding silos for 3 - 4 days. It is then returned to the machine feed silos and from there, injected into the box molds. Before injecting the polystyrene, the operator positions the profiles, welded mesh, finishes (wood-cement fiber or brick) and the brackets (for the reinforced version) in the mold.

After closing the molds, steam is injected under pressure for several minutes and causes the polystyrene beads to weld together and adhere to the different constituents while trapping the steel frame. The whole thing is then cooled by water.

If the finish chosen is a protective primer, the latter will be sprayed at the factory on the exterior face of the trunk.

2.8.1.5. Assembly with side panels

After the trunk is lengthened, the polypropylene cheeks are pressed against the ends of the trunk and lowered to allow the points to penetrate the expanded polystyrene.

The extra thicknesses clip into the aluminum profiles and a wedging device ensures definitive fixing.

For BSO boxes, after the box has been lengthened, the polystyrene sides are glued with silicone glue or with one-component polyurethane glue.

2.8.2. Controls

The self-checks provided below, to the extent that they are properly carried out, appear likely to ensure the consistency of the quality of the products.

2.8.2.1. Terracotta facing

- Density: $2000 \pm 200 \text{ kg/m}^3$ • Nominal thickness: 8 mm - tolerance compared to the nominal thickness of $\pm 1 \text{ mm}$ • Width: $278 \text{ mm} +0 -3 \text{ mm}$ • Length: $495 \text{ mm} +5 -0 \text{ mm}$
- A separation, each plate is controlled in a template. Parts

with defects or cracks are discarded.

2.8.2.2. Fibragglo plates

- Density: $600 \pm 30 \text{ kg/m}^3$ • Nominal thickness: 5 to 8 mm • Length: $2 \text{ m} +5 -0 \text{ mm}$

The 2 meter long panels are cut to the desired widths. Parts that do not have sufficient strength break during handling and are scrapped.

2.8.2.3. Protective primer

The operator visually checks the regularity of the appearance of the projected protective primer. If necessary, it will go back to the area not covered sufficiently. The quantity applied at the factory is a minimum of 0.2 l/m^2 .

2.8.2.4. Expanded polystyrene

- Reaction to fire classification: E
- Density: $30 \pm 2 \text{ kg/m}^3$

2.8.2.5. Fibragglo-polystyrene complex

- Resistance to tearing (MPa): $> 0.2 \text{ daN/cm}^2$

2.8.2.6. Terracotta-polystyrene complex

- Resistance to tearing (MPa): $> 0.2 \text{ daN/cm}^2$

2.8.2.7. Fibragglo-polystyrene complex

- Resistance to tearing (MPa): $> 0.2 \text{ daN/cm}^2$

2.8.2.8. Terracotta-polystyrene complex

- Resistance to tearing (MPa): $> 0.2 \text{ daN/cm}^2$

2.8.2.9. Steel trellis and aluminum rail

The purchasing manager carries out a visual inspection (dimension, welding, condition) upon delivery.

2.8.2.10. Quality of chests

Operators check during production:

- Dimension: interior width and height of the trunk; parallelism of the walls
- Polystyrene: cooking and general condition (hole...)
- Mesh: not visible

- Rail: held in polystyrene; positioning Finish: adhesion of

• Fibraggio or terracotta panels; absence of crack In the event of a defect, the production manager intervenes to adjust the settings of the machines and the box is scrapped.

2.8.2.11. Polypropylene cheeks

Each part is checked after injection.

Once a week, cheeks are mounted for inspection.

2.8.2.12. Pre-expansion of polystyrene

Control of the density at each cycle during pre-expansion.

The weighing of the material and the volume of the pre-expansion are done automatically.

2.8.3. Storage – Delivery (see Figure 42)

When leaving the press, the boxes are visually inspected, packaged, marked, labeled and stored.

Storage is done on level ground, the boxes must be placed on rails or pallets, in order to avoid an overhang. The boxes must also be protected from bad weather (frost, rain, sun, etc.).

2.8.4. Commercialisation

The chests and accessories are sold to closure manufacturers, traders or carpentry or masonry companies.

The boxes are delivered in a length of 6 m, not equipped with side panels. They can also be supplied cut to the requested lengths and equipped or not with side panels.

2.8.5. Assembly at the distributor

Before machining, the boxes must be stored indoors (48 hours minimum) to limit the risks linked to thermal shock or to evacuate humidity which could alter the mechanical properties of the materials during flow and assembly in particular.

The 6 ml boxes will be cut into different sections in order to obtain the desired lengths.

The flow rate will correspond to the board width (with finishing coating) plus 19 cm (2 x 95 mm) or 13 cm (2 x 65 mm) depending on the cheek model. Example: For a panel width of 1000 mm, the box will be debited at 1190 mm.

Several saws can be used (band saw, diamond blade, cutting disc, etc.) to cut the different materials constituting the boxes (polystyrene, aluminum, steel, wood-cement fiber, brick, etc.). The choice of tooling will mainly depend on the performance objectives.

The soffits and rail covers will be cut 10 mm greater than the panel width. The installer will have to adapt the underside on the site

2.8.6. Installation of the roller shutter

The assembler can also mount a roller shutter in the trunk. The underside can be mounted on the trunk or delivered as a supply.

2.8.7. Packaging and transport

The chests will be stored flat according to the sketch below.

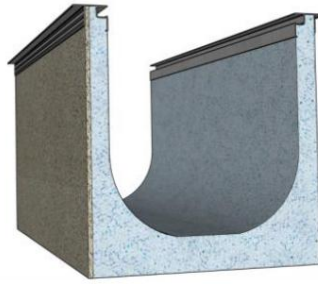

Figure 16 - Store the chest lying flat

The boxes must be palletized and strapped to ensure proper support during transport.

The pallet must be stored protected from bad weather (frost, rain, sun, etc.) and shocks, thus avoiding damage to the goods.

2.8.8. On-site storage

- The chests must be stored flat and protected from bad weather.
- The operator must ensure the conformity of the goods (width of the boxes, model, quality of goods, etc.) and take note of the recommendations described in the Technical Notice before implementation.

2.9. Mention of supporting documents

2.9.1. Experimental results

Thermal performance

CSTB report of November 2, 2016 reference DEIS/HTO-2016-1876BB/LS-N°SAP70055426

Air permeability and wind resistance

CSTB report: DSSF-VTI-JFR/MB-2014-1112 of JULY 10, 2014

The wind tests were carried out on reinforced boxes type 28 and 30. The reinforcements were spaced 1200 mm apart.

The air permeability tests were carried out on a one meter board box (without reinforcement) and on type 28 and 30 reinforced boxes with a width of 450 cm board.

TYPE	1,19 m CVR 30	4,69 m CVR 28
PERMEABILITE A L'AIR	Class c*3	Class C*3

Acoustic performance

CSTB report No. AC16-26064802 dated 11/24/2016 Determination of acoustic insulation according to standards NF EN ISO 10140-1 (2013), NF EN ISO 10140-2 (2013), NF EN ISO 10140-4 (2013), NF EN ISO 10140-5 (2013), NF EN ISO 12999-1 (2014) and NF EN ISO 717-1 (2013).

ECAM RICERT test report n°ACOU-14-4393-001/F of August 28, 2014 Determination of acoustic insulation according to standard NF EN ISO 717/1.

ECAM RICERT test report n°ACOU-14-4393-002/F of August 28, 2014 Determination of acoustic insulation according to standard NF EN ISO 717/1.

ECAM RICERT test report n°ACOU-14-4393-003/F dated August 28, 2014 Determination of acoustic insulation according to standard NF EN ISO 717/1.

ECAM RICERT test report n°ACOU-14-4393-004/F of August 28, 2014 Determination of acoustic insulation according to standard NF EN ISO 717/1.

Adhesion of finishes

ECAM RICERT test report n° 13-291-004 of MARCH 4, 2013

- Results of adhesion tests of a single-layer coating (according to EN 1015-12:2002) on coated polystyrene support of a terracotta plate.

ECAM RICERT test report n° 15-2268-003 of APRIL 16, 2015

- Results of adhesion tests of hardened coating mortars applied to supports (according to EN 1015-12:2002) on polystyrene support.

ECAM RICERT test reports n° 16-1006-001/F/B and 16-1006-002/F/B of 10/01/2017

- Results of adhesion tests of a single-layer coating (according to EN 1015-12:2002) on coated polystyrene support a layer of protective primer.

Mechanical tests

Fixolite test report from June 13, 2017:

- Traction of the fixings in the aluminum profile of the Brise-Soleil boxes

2.9.2. Construction site references

This system with lintel anchors of a similar design has been used in Germany for 30 years. It has also been used since 1981 in France where more than 2,000,000 ml have been installed to date.

Among the latest achievements we can cite:

- Collective: Jardins de MANET, 44-Nantes. • Collective: Jardins de CAMUS, 44-Nantes • Specialized Welcome House: L'Espelidon, 84-Avignon • 15 town houses: Allées de Médicis, 33-Bordeaux Cauderan, • Gendarmerie: 24-Trélassac, • 16 housing units 2 buildings: 63-Issoire, • Housing development: "Les Vignes Rouges", 74-Sévrier • Individual house: 07130 Saint Peray - 2016 • Individual house: 35 Argentré du Plessis - 2015 • Individual house: 35 Domloup - 2015 • Individual house: DB Matx 84 Vaucluse - 2015 • Individual house: MEDEX 13 Bouches du Rhône - 2015

- Individual house: MAP 83 Var - 2015
- Individual house: Bella Vista 13 Bouches du Rhône - 2015
- Individual house: Le Scanff: 29 Quimper - 2016
- Individual house: Camus: 56 - 2016
- Individual house: Langle: 56 Séné - 2016 • Individual house: Robo-Yaouanq: 56 Ploemeur – 2016

2.10. Annex to the Technical File – Implementation plans

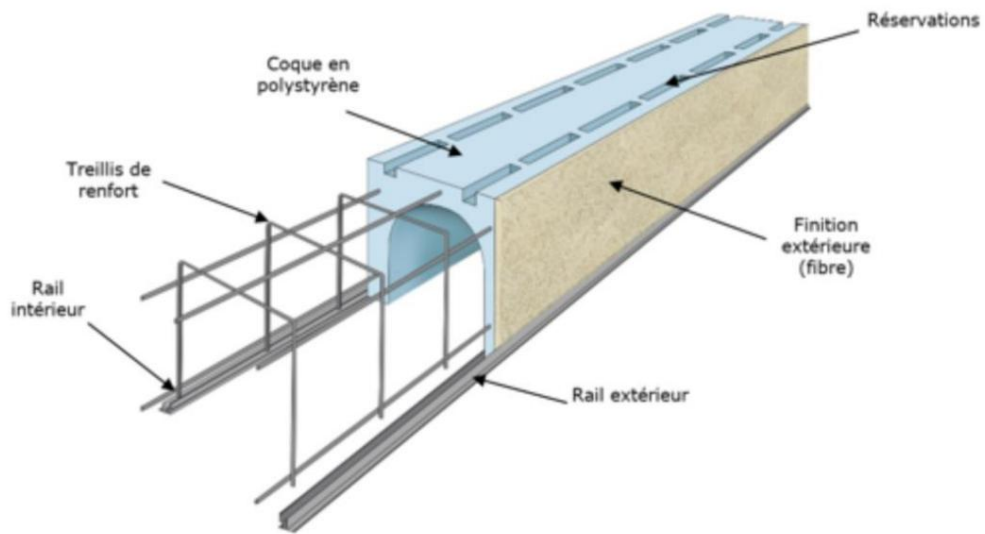

Figure 17 - Composition of a chest

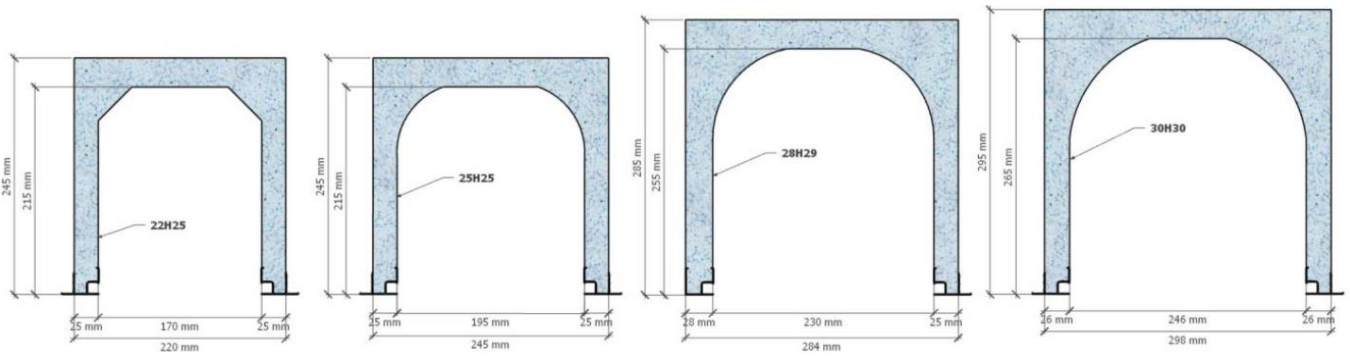

Figure 18 - Traditional chests

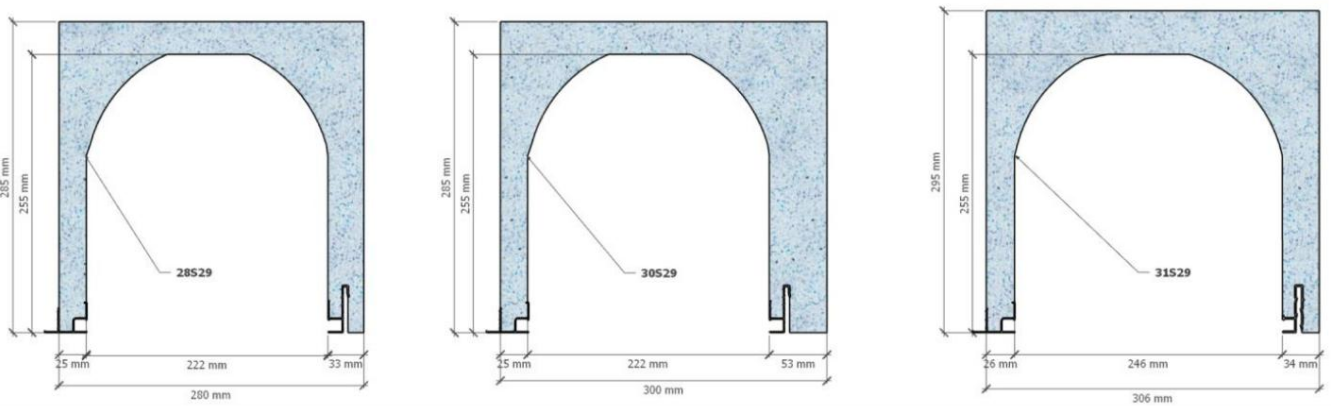

Figure 19 - High insulation boxes

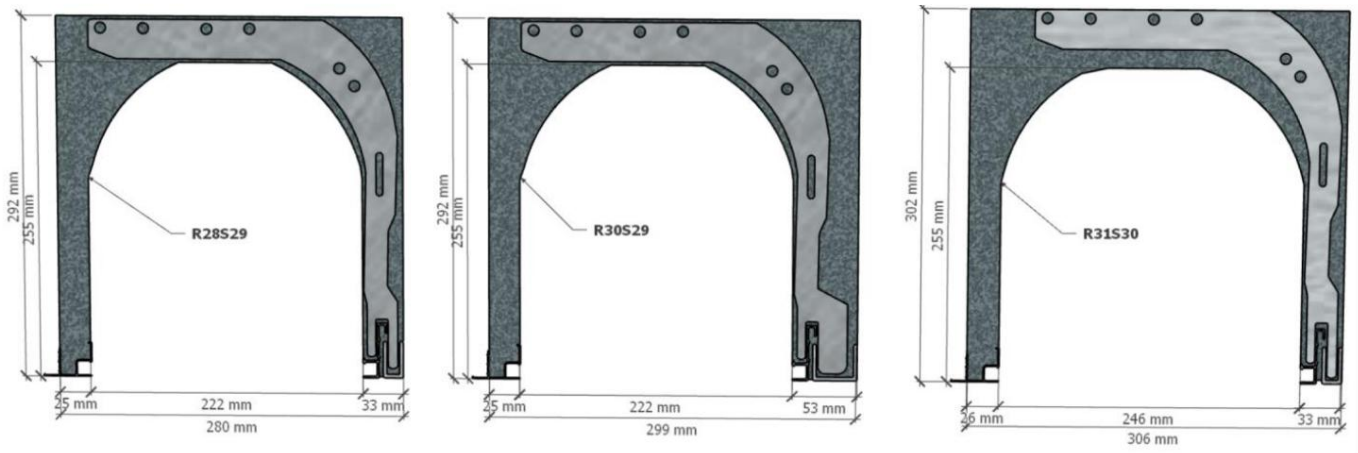

Figure 20 - Reinforced chests

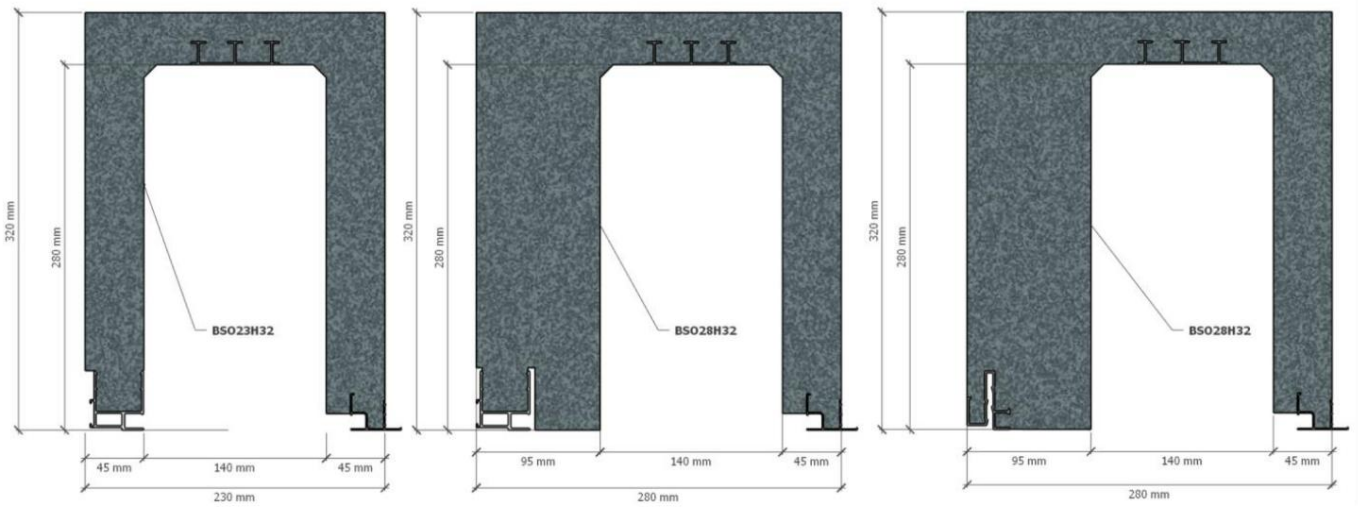

Figure 21 - BSO boxes with PVC or aluminum rail

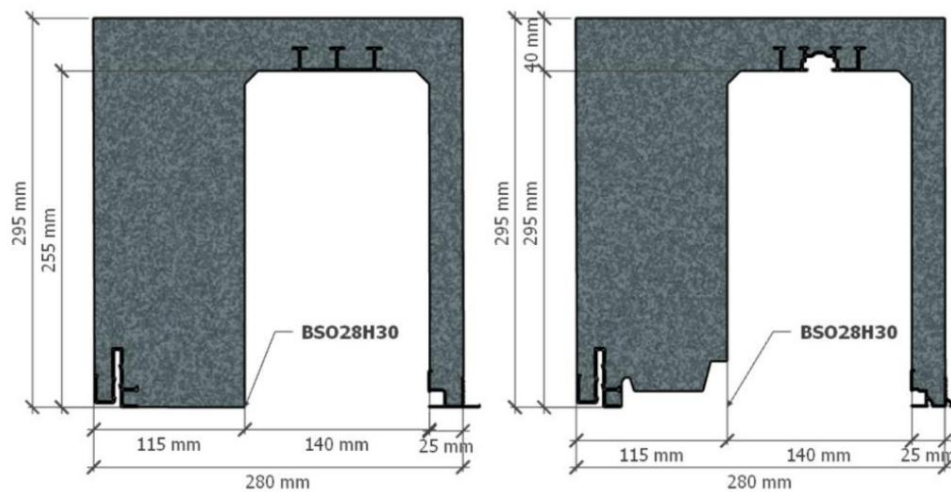

Figure 22 - BSO boxes with 115 mm interior wall

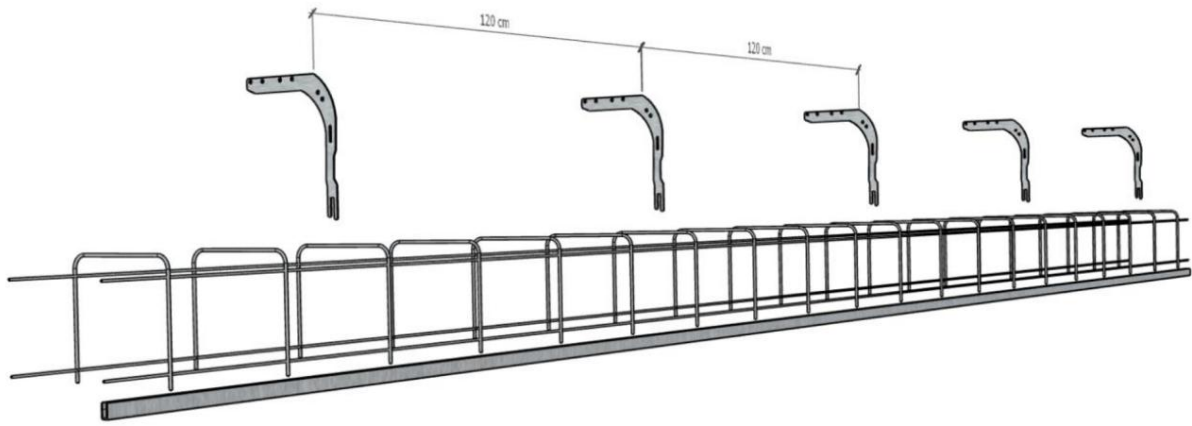

Figure 23 - Reinforcement brackets (every 120 cm) and U-shaped reinforcement

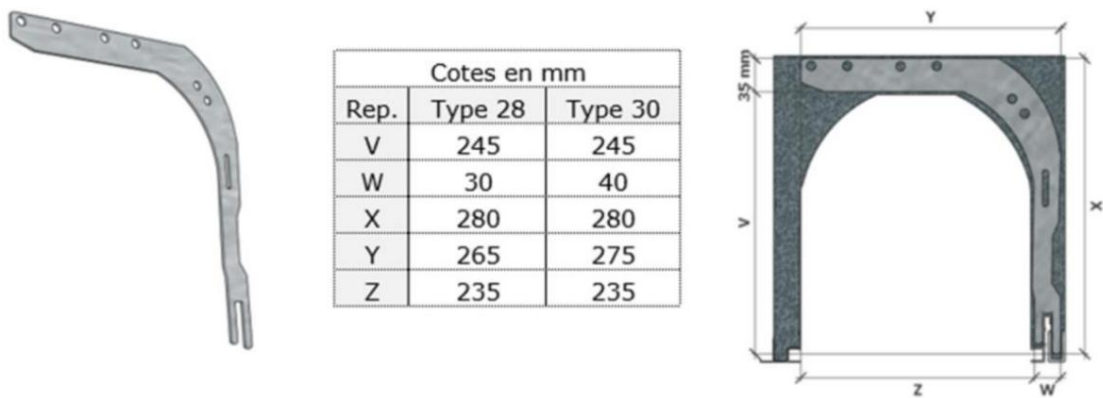

Figure 24 - Galvanized steel reinforcement for reinforced boxes

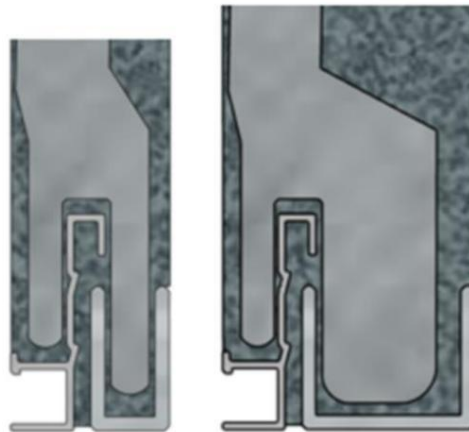

Figure 25 - U-shaped reinforcement rail

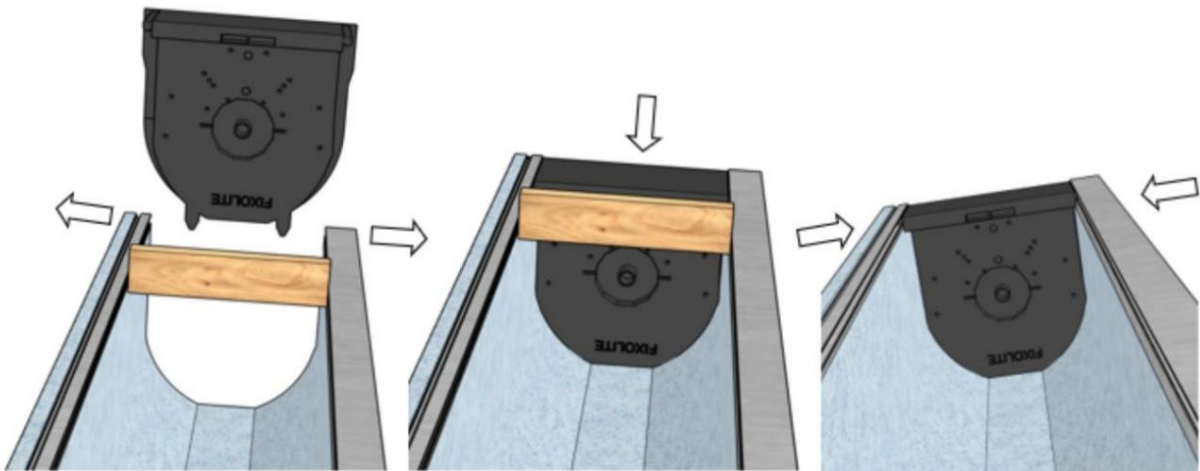

Figure 26 - Assembling the cheeks on the trunk

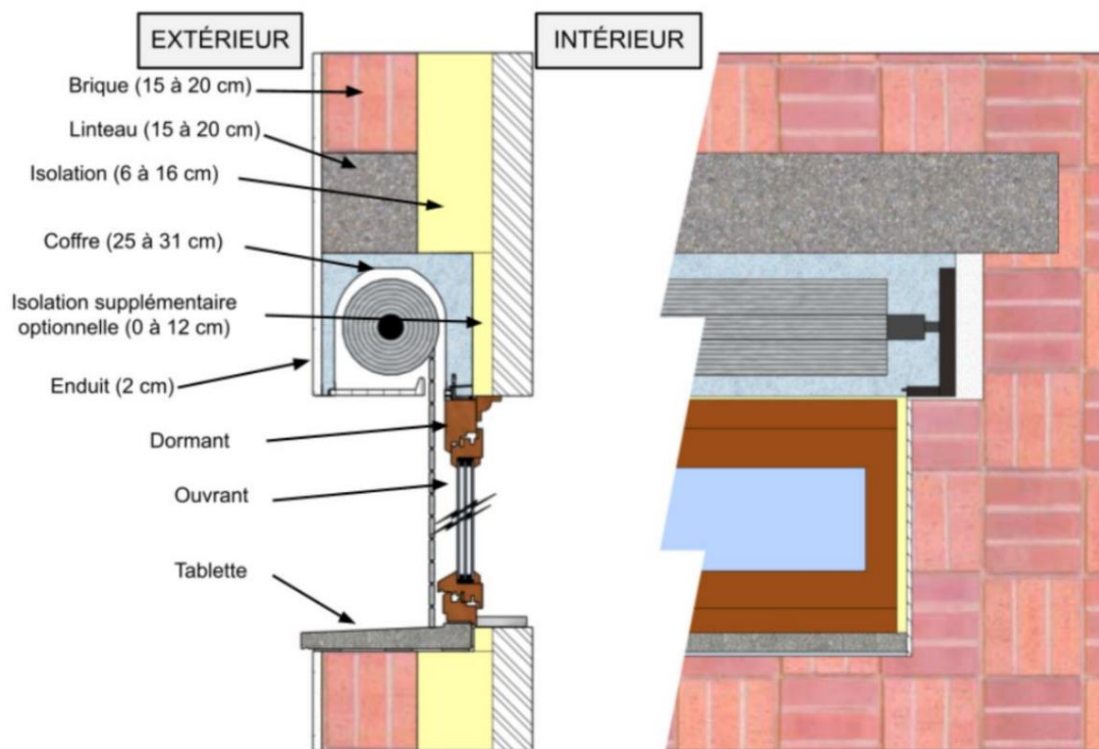
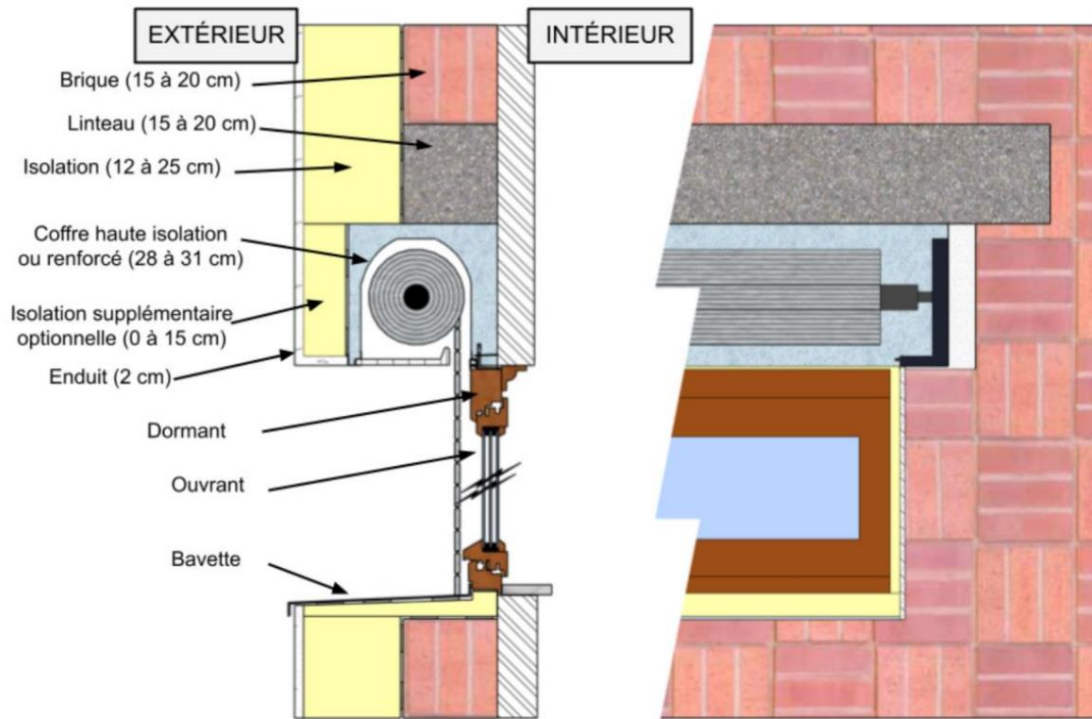

Figure 27 - Implementation for internal thermal insulation (ITI)



Note: The values in parentheses correspond to the thicknesses.

Figure 28 - Implementation for external thermal insulation (ITE)

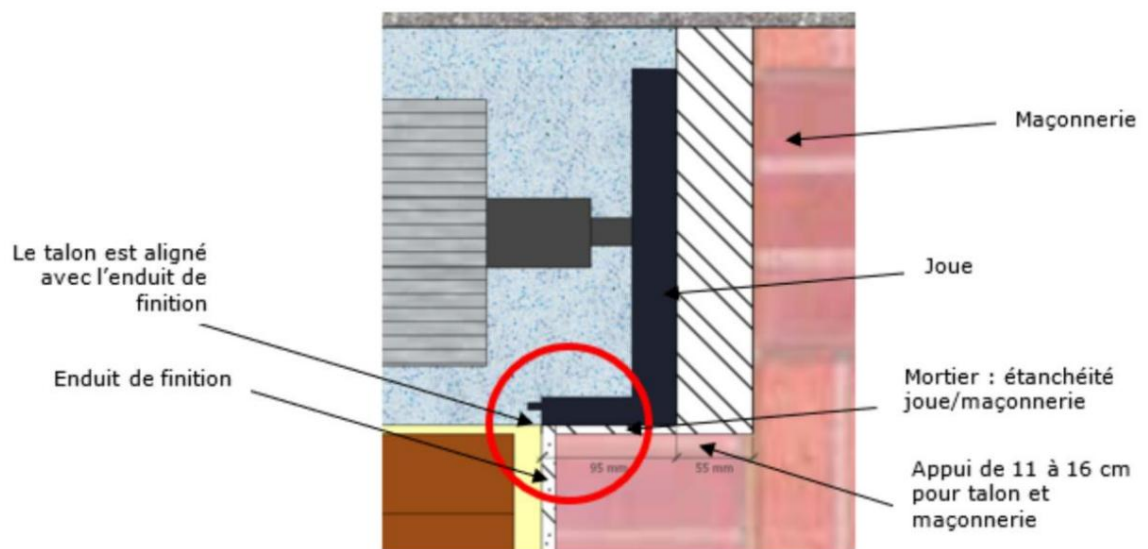

Figure 29 - Heel of the cheek aligned with the finishing coating

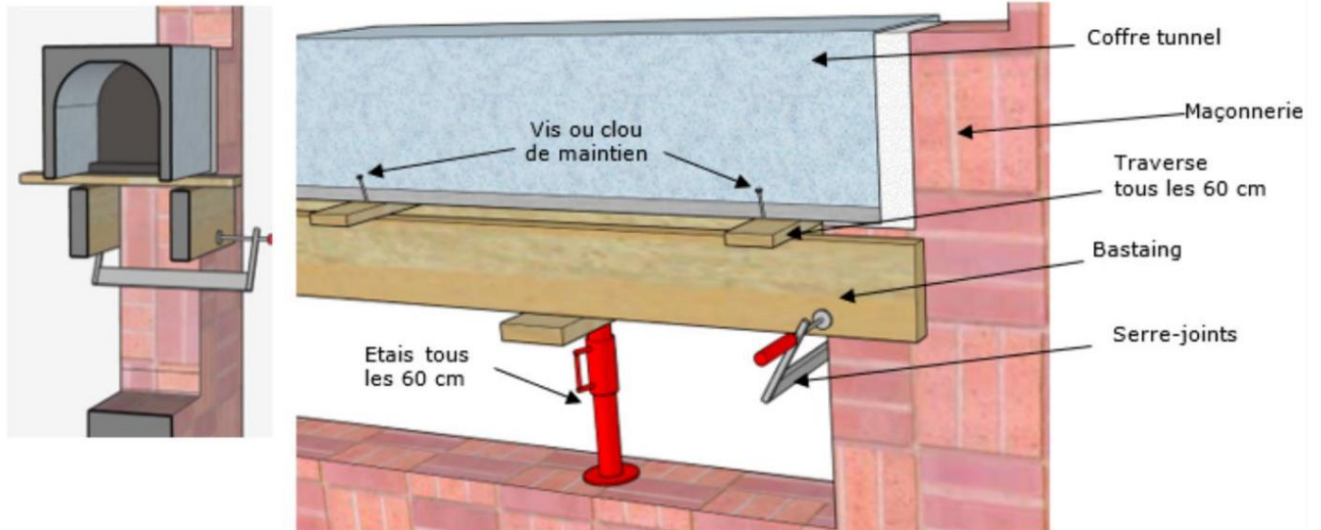

Figure 30 - Installation with clamps and props

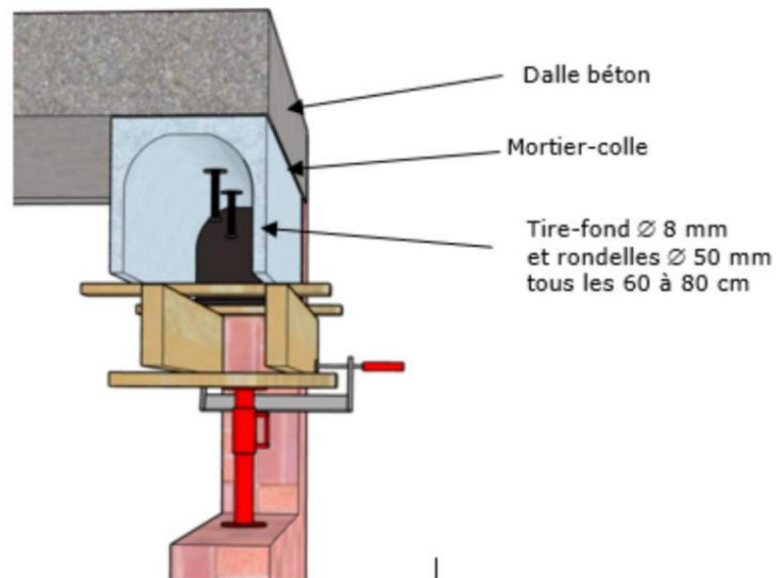

Figure 31 - Installation under slab with lag screws placed every 60 to 80 cm

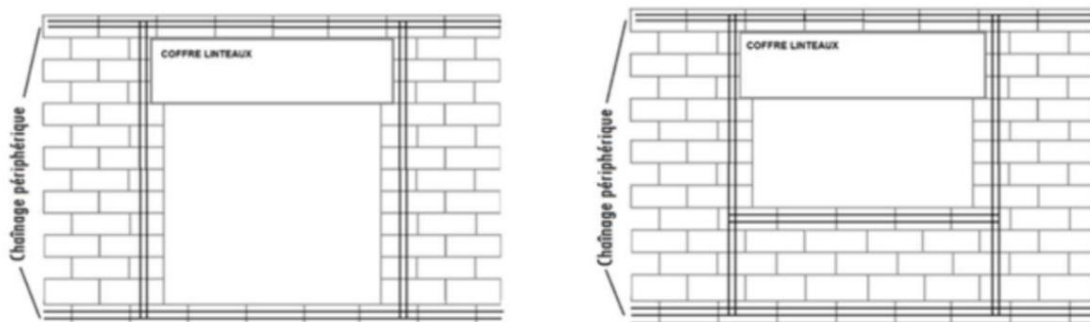

Figure 32 - Chaining of French windows and doors for seismic treatment



Figure 33 - Cutout of the rail (coating support part) – exterior view

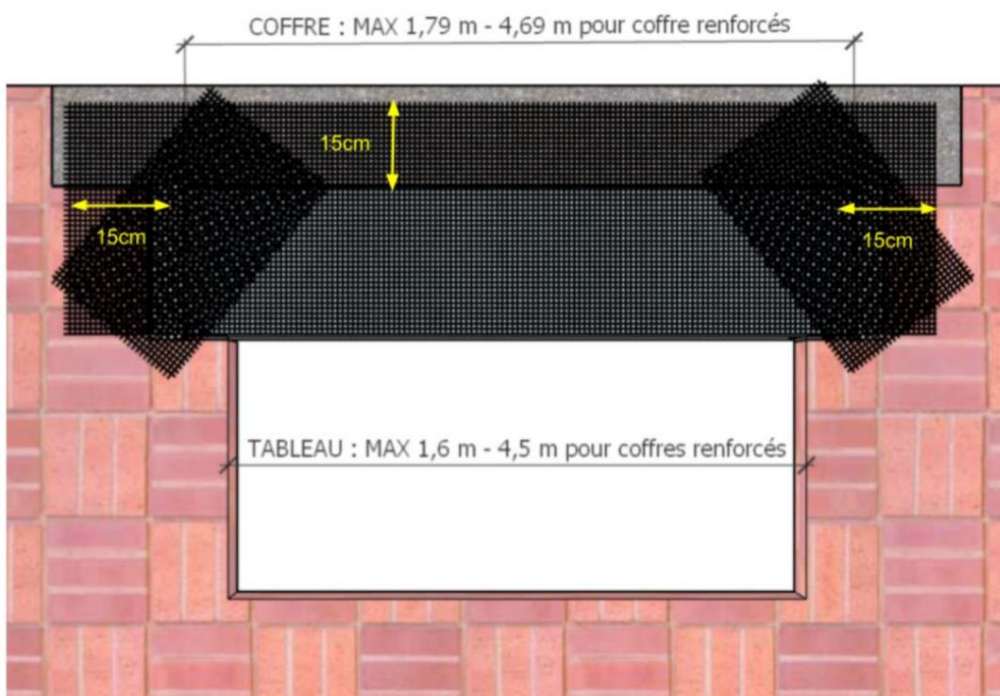
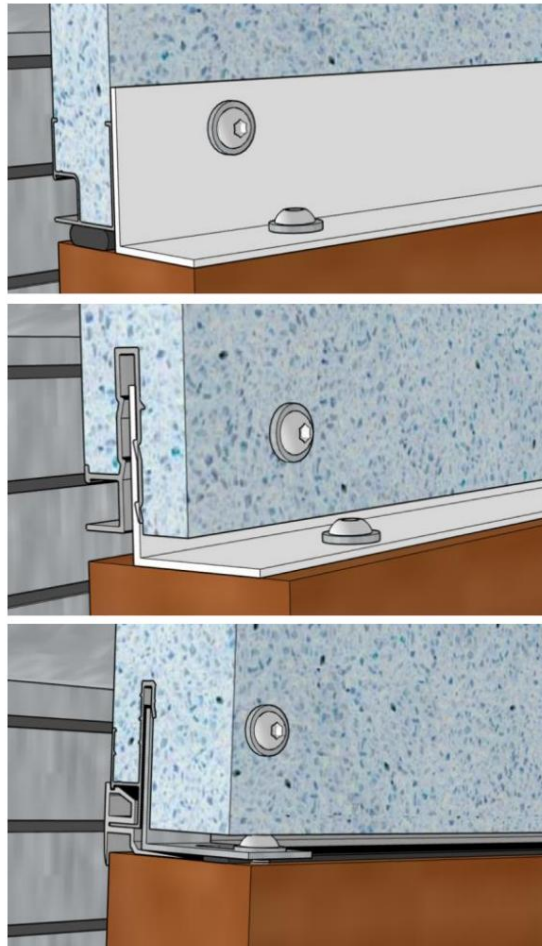

Figure 34 - Reinforcing mesh embedded in the coating



Rail 8H

Fixing with PVC angle and screws.

A foam seal or EPDM can be placed under the rail

Rail 8R

Fixing with PVC angle and screws.

A foam seal or EPDM can be placed under the rail

Rail 8E

Fixing with J8 seal (for external winding).

Fixing with brackets and screws (for HI box with 53 mm wall).

Figure 35 - Fixing the interior wing to the joinery frame

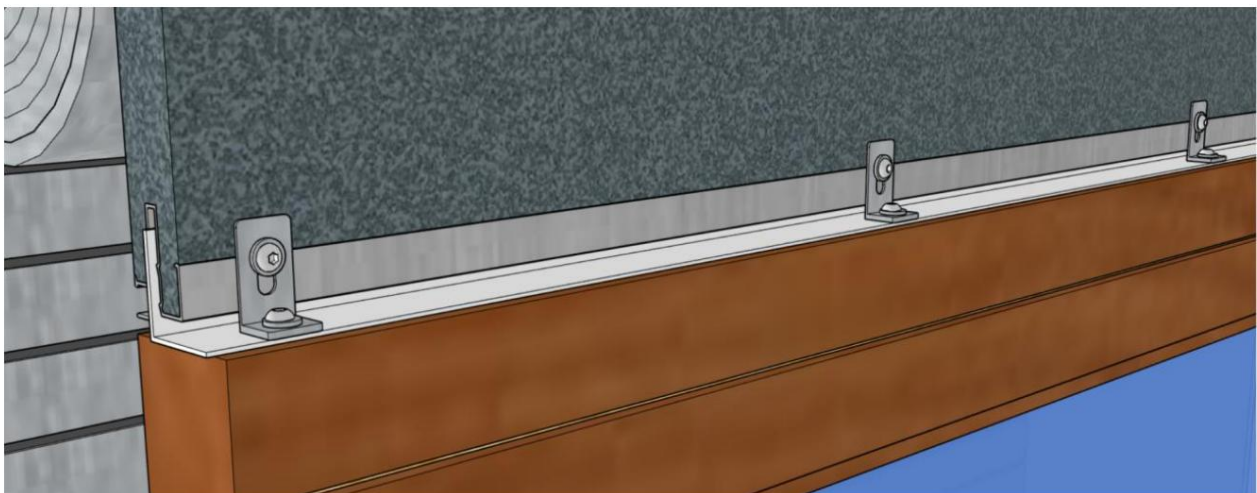

Figure 36 - Angle and connecting bracket with the frame for reinforced box

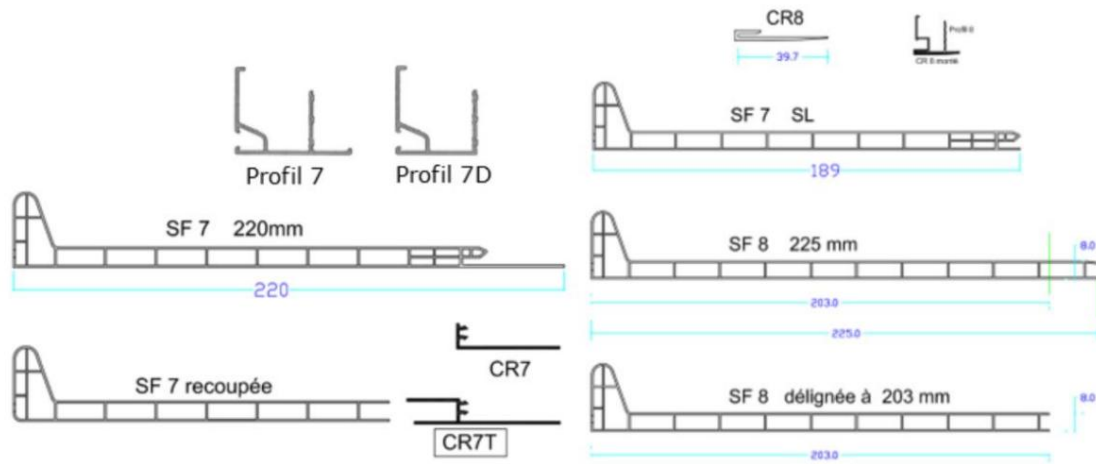

Figure 37 - Sous-faces (SF) et cache-rails (CR)

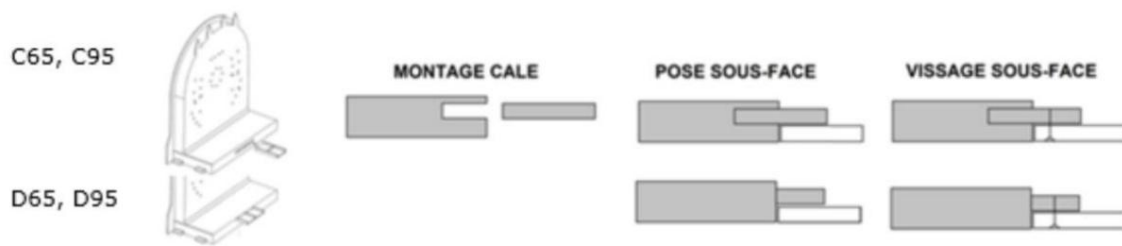

Figure 38 - Fixing the underside with wedges

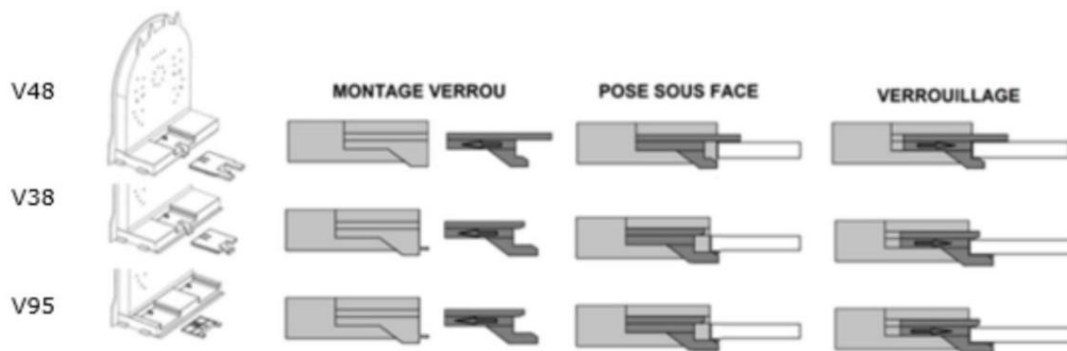

Figure 39 - Fixing the soffit with locks

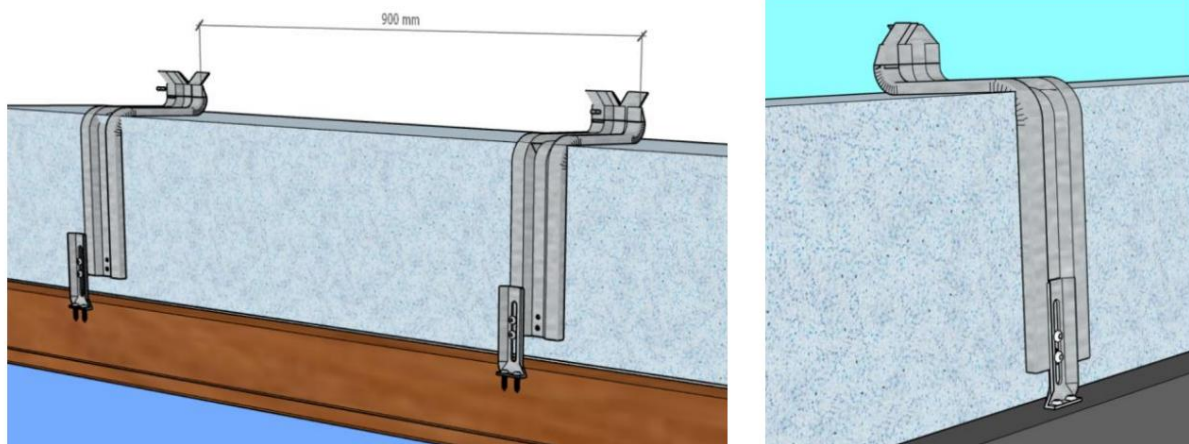

Figure 40 - RT2830 reinforcement allowing the joinery to hold to the lintel

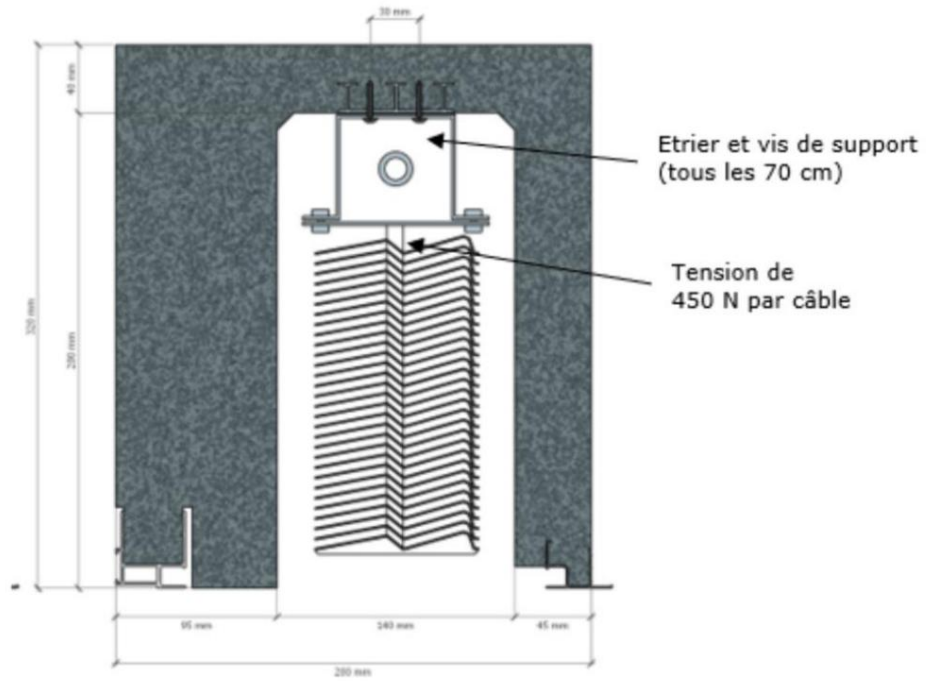

Figure 41 - BSO box with BSO mounted



Figure 42 - Pallet of chests in stock, ready for delivery